

磁粉检测报告

Inspection Report of magnetic powder

报告编号 Report No: 1705-025 第 1 页共 2 页 Page 1

委托单位 Client	新乡市德工机械有限公司 XINXIANG DEGONG MACHINERY CO., LTD		样品编号 Sample No.	001/002 NO.1/NO.2	工件名称 Workpiece name	滑轮 pulley	
工件材质 Material	45	磁化规范 Magnetization standard	磁轭法 > 44N 提升力 Yoke method > 44N lifting power	仪器型号 Instrument model	CDX-III	灵敏度 试块 Sensitivity	A1-30/100 型 A1-30/100 type
检测比例 Inspection ratio	100%	探伤部位 Flaw detection part	焊缝 Weld line	磁粉, 磁悬液 Magnetic powder, magnetic ink	黑水磁悬液 HD-BW	验收标准 Acceptance	JB/T6061-2007 2 级 JB/T6061-2007 Grade 2
磁化方法 Magnetization method	磁轭法 Yoke method	表面状态 Surface state	外观合格后 Appearance qualification	工件规格 Specification	Φ1152 mm	磁化时间 Magnetization time	1~3 S
检测地点 Inspection place		公司车间 Company workshop		检测日期 Inspection date		2017.06.29	
工件编号 workpiece No.	检测部位 Inspection part			评定结果 result	缺陷性质 Flaw property	缺陷长度(mm) Length of flaw	评定意见 Evaluation
001 NO. 1	轮毂焊缝 Hub Weld line			未见缺陷 No flaw	/	/	合格 qualified
002 NO. 2	轮毂焊缝 Hub Weld line			未见缺陷 No flaw	/	/	合格 qualified

检测示意图/ Test Diagram

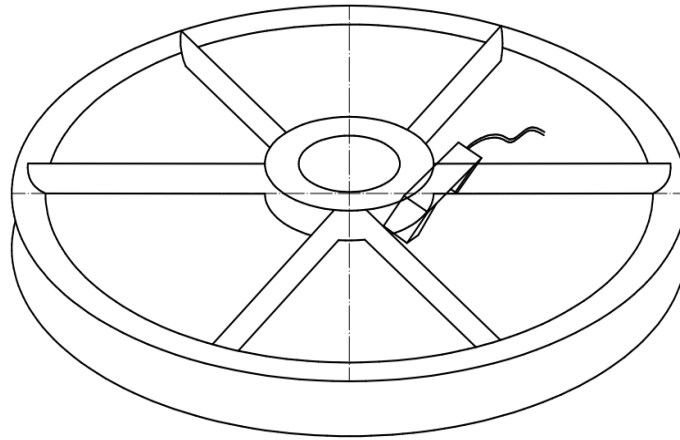

累计检测面积
Total inspection length

整个滑轮环形焊缝
Annular weld across the pulley

累计返修长度 mm
Total repair length mm

/

结论：经磁粉检验，所检滑轮符合 JB/T6061-2007 2 级标准规定，评为合格。

Conclusion : After the magnetic particle inspection, the inspected pulleys are in accordance with the 2 grade standard specified in JB/T6061-2007, rated as eligible.

检测：毛小炜

Inspector: 毛小炜

审核：韩超

Checked by: 韩超

